

Name _____ Period _____ Date _____

Area of Triangles 2

1) A= _____

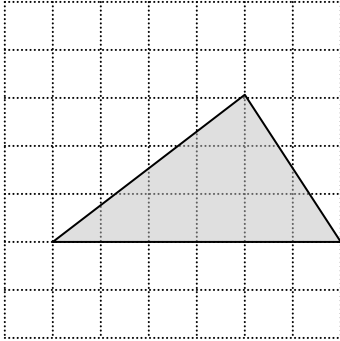

2) A= _____

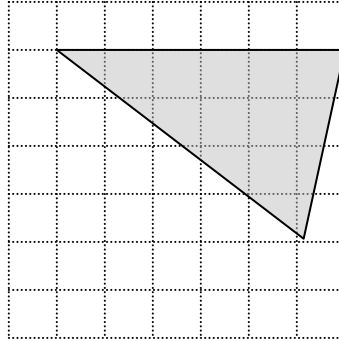

3) A= _____

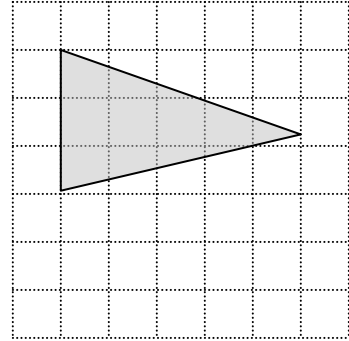

4) A= _____

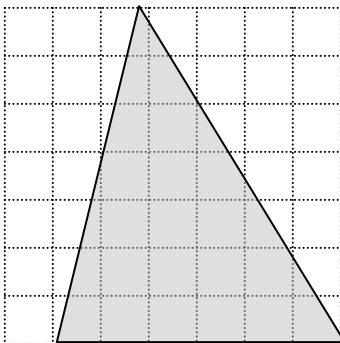

5) A= _____

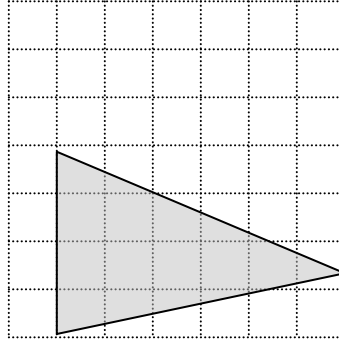

6) A= _____

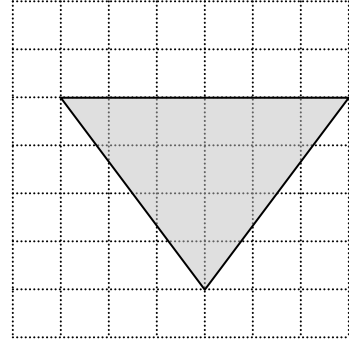

7) A= _____

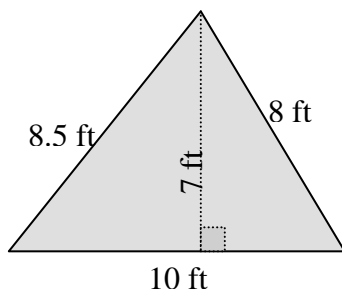

8) A= _____

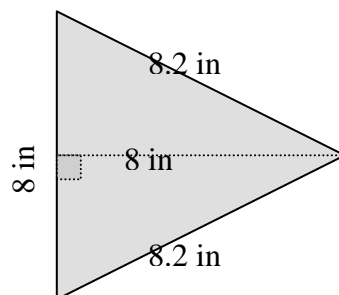

9) A= _____

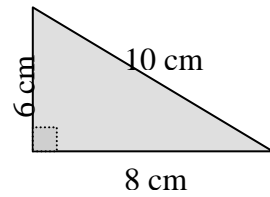

10) A= _____

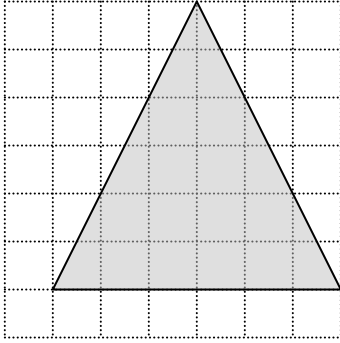

11) A= _____

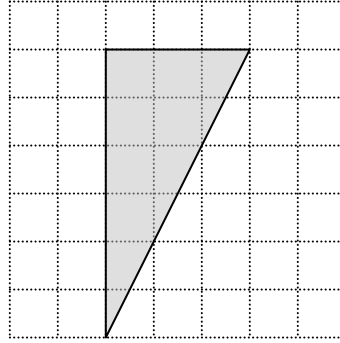

12) A= _____

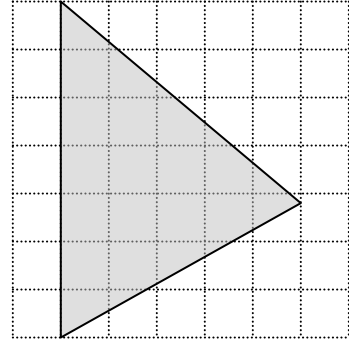

13) A= _____

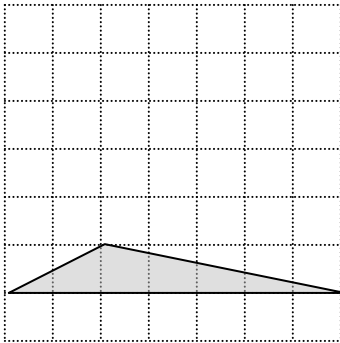

14) A= _____

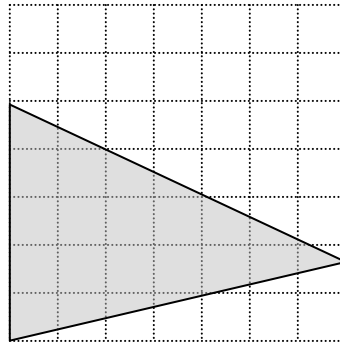

15) A= _____

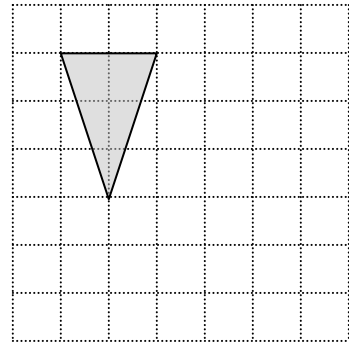

16) A= _____

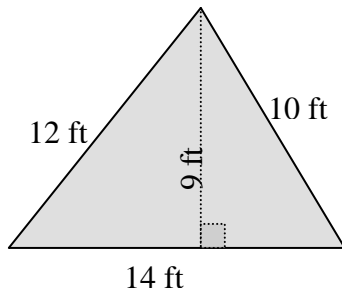

17) A= _____

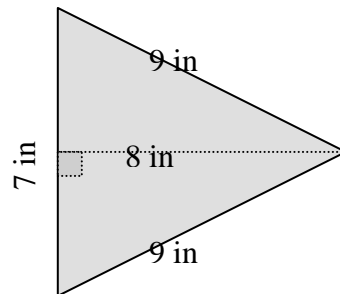

18) A= _____

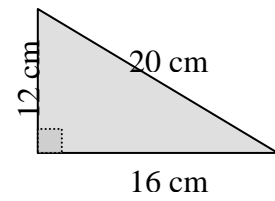

Name ANSWER KEY Period _____ Date _____

Area of Triangles 2

1) A=9 squares

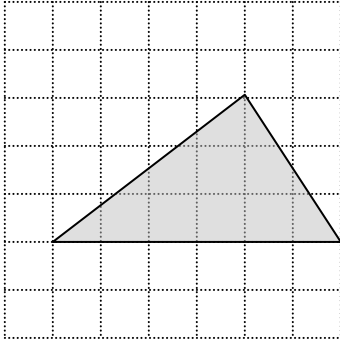

2) A=12 squares

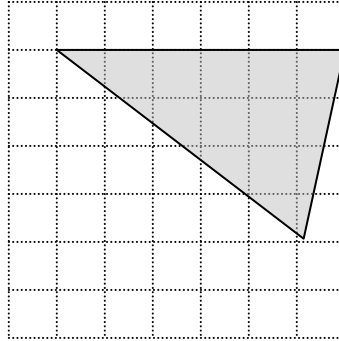

3) A=7.5 squares

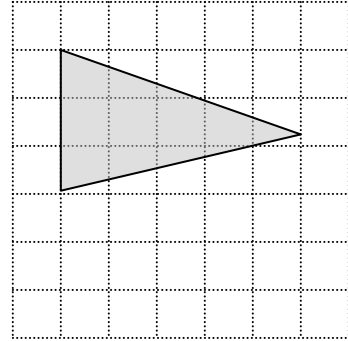

4) A=21 squares

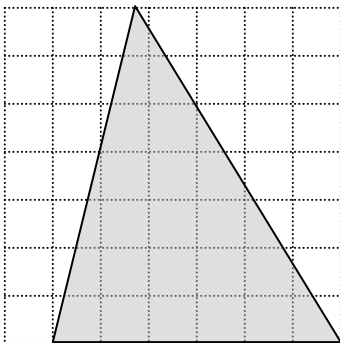

5) A=9 squares

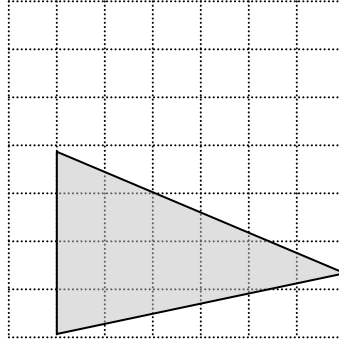

6) A=12 squares

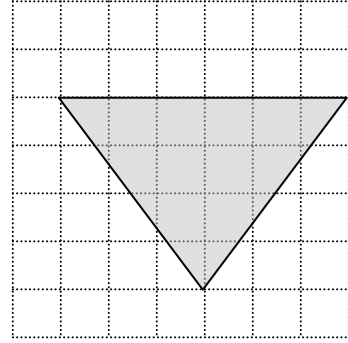

7) A=35 sq. ft.

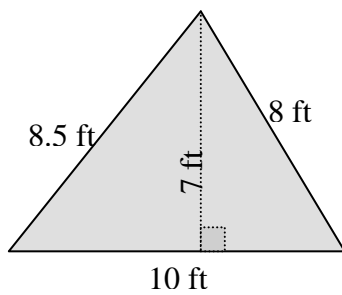

8) A=32 sq. in.

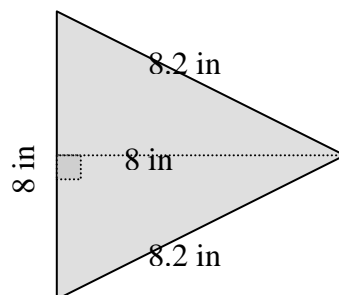

9) A=35 sq. ft.

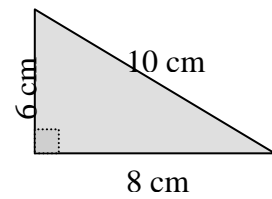

10) A=21 squares

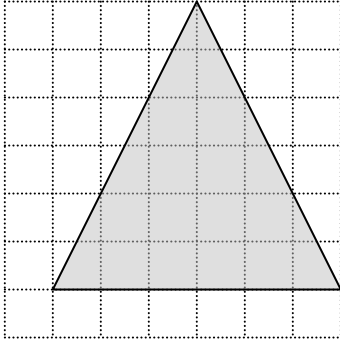

11) A=9 squares

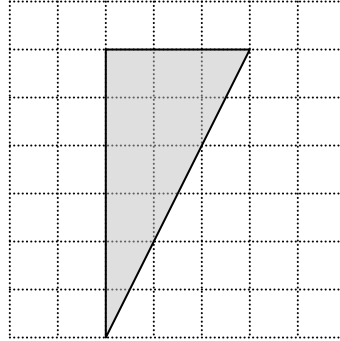

12) A=17.5 squares

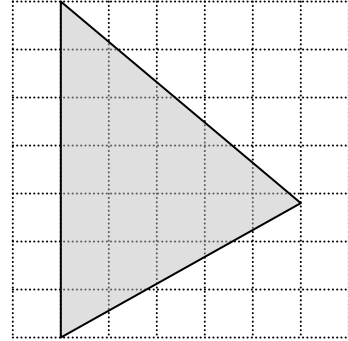

13) A=7 squares

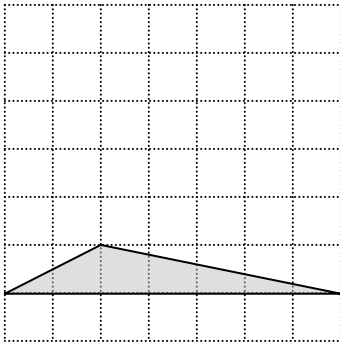

14) A=17.5 squares

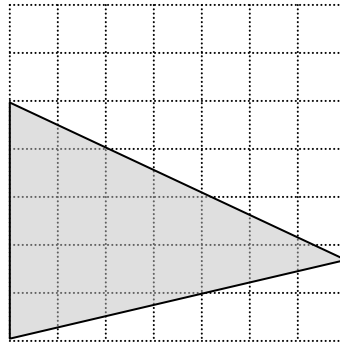

15) A=3 squares

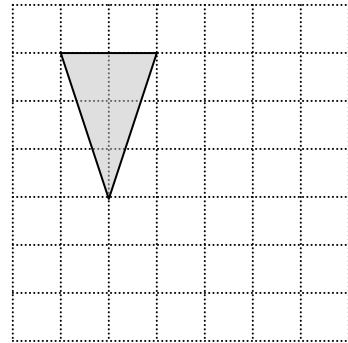

16) A=63 sq. ft.

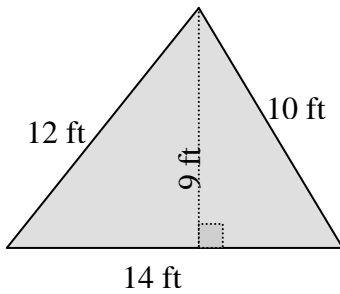

17) A=28 sq. in.

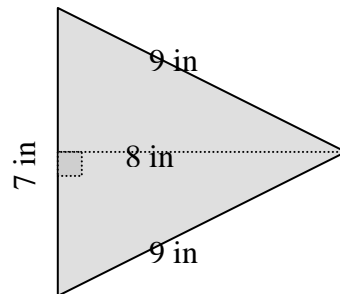

18) A=192 sq. cm.

